



## The Choice of Professionals

### King Bros. Industries

29101 The Old Road, Valencia, CA 91355

Toll Free: (800) 325-9468 Fax: (661) 257-4320

E-mail: valves@kbico.com Web: www.kbico.com

# Anti-Freeze Drain Valves

## Features:

- Protects irrigation systems that are subject to freeze damage by automatically opening and allowing water to drain when system is shut off.
- Valve opens to allow system to drain at low pressure (8-10 psi.) and has check valve to prevent muddy backflow water from entering system.
- Large diameter ribbed area allows for hand installation.
- Special fiber outlet allows efficient drainage, while keeping debris and roots from fouling valve.
- Meets/Exceeds ASTM & ANSI standards.
- All ABS plastic and EPDM rubber construction resists corrosion.
- Molded in the **USA** by KBI.

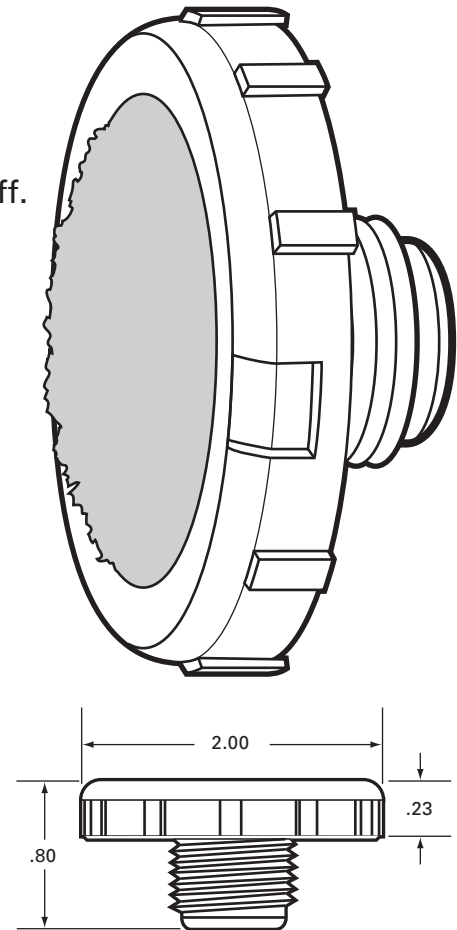

Model	Size	Description	Case	W
AFD-0500	1/2"	MIPT x Screen	200	6.1
AFD-0750	3/4"	MIPT x Screen	200	7.6

## FEATURES COMMON TO KBI PLUMBING PRODUCTS

- Molded in the USA by KBI
- Made with ABS plastic and EPDM rubber
- Meets/Exceeds all ASTM Standards
- Limited LIFETIME Warranty

