



## The Professional's Choice

### King Bros. Industries

29101 The Old Road, Valencia, CA 91355

Toll Free: (800) 325-9468 Fax: (661) 257-4320

E-mail: valves@kbico.com Web: www.kbico.com

# CPVC Economy Ball Valves

## Features:

- EPDM stem seal.
- NSF listed & IAPMO (UPC) listed.
- Patented Cam-lok design #5,308,039.
- Full Port Design.
- Complies with all ASTM & ANSI standards.
- Made with **PlatinumXCELL**® CPVC.
- Molded in the **USA** by Kbi.
- Pressure-Temperature rating:
- Pressure Rated to 100 psi @ 180°F  
Nominal operating pressure.

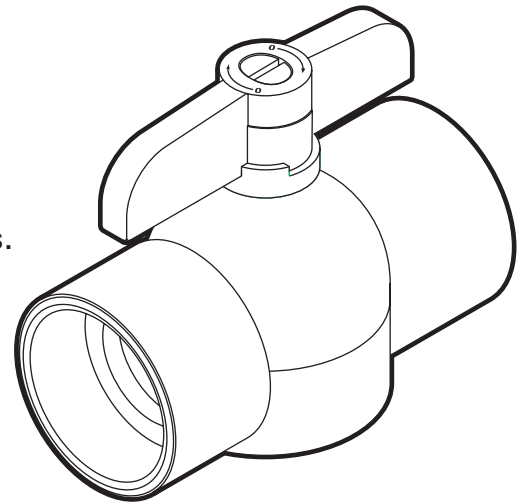

Model	Size	Case	L	D	H
CBV-0500-BH	1/2"	36	2.3"	.85"	2.0"
CBV-0750-BH	3/4"	24	3.1"	1.1"	2.4"
CBV-1000-BH	1"	18	3.7"	1.7"	2.8"
CBV-1250-BH	1 1/4"	6	5.0"	2.9"	4.2"
CBV-1500-BH	1 1/2"	6	5.5"	3.0"	4.4"
CBV-2000-BH	2"	4	6.8"	4.0"	5.2"

## FEATURES COMMON TO KBI CPVC PLUMBING PRODUCTS

- NSF listed \*
- IAPMO (UPC) listed \*
- Molded in the USA by KBI
- Pressure rated to 100 psi @180°F
- Meets/Exceeds all ASTM Standards
- Made with PlatinumXCELL® CPVC
- Limited LIFETIME Warranty

