



The Choice of Professionals

King Bros. Industries

29101 The Old Road, Valencia, CA 91355

Toll Free: (800) 325-9468 Fax: (661) 257-4320

E-mail: valves@kbico.com Web: www.kbico.com

10 LB Spring Check Valve (Hose)

Features:

- 10 pound spring gives positive seal with no back pressure
- Meets/Exceeds ASTM & ANSI standards.
- Made of High-Impact PVC Type II material.
- Molded in the **USA** by KBI.
- 150 psi working pressure (*tested to 500 psi static @ 72°F*).

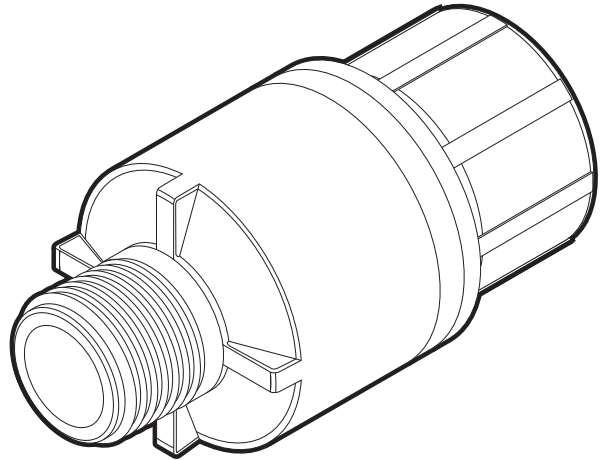

Model	Size	Description	Case	Weight
PS-0500-LS	3/4"	FHT x MHT	Call	Call

FEATURES COMMON TO KBI PVC PRODUCTS

- NSF listed *
 - Molded in the USA by KBI
 - Limited LIFETIME Warranty
 - 150 psi working pressure (*tested to 500 psi static @ 72°F*)
 - Meets/Exceeds all ASTM Standards
 - Made with Hi-Impact PVC Type II Cell Class 15344-C
- * See individual products for details

