



The Choice of Professionals

King Bros. Industries

29101 The Old Road, Valencia, CA 91355
 Toll Free: (800) 325-9468 Fax: (661) 257-4320
 E-mail: valves@kbico.com Web: www.kbico.com

Swing Check Valve

Features:

- Swing Check insignificant pressure loss due to full flow design.
- Meets/Exceeds ASTM & ANSI standards.
- Made of High-Impact PVC Type II material.
- Molded in the **USA** by KBI.
- Swing Check is not recommended to be installed with outlet side angled down or facing down.

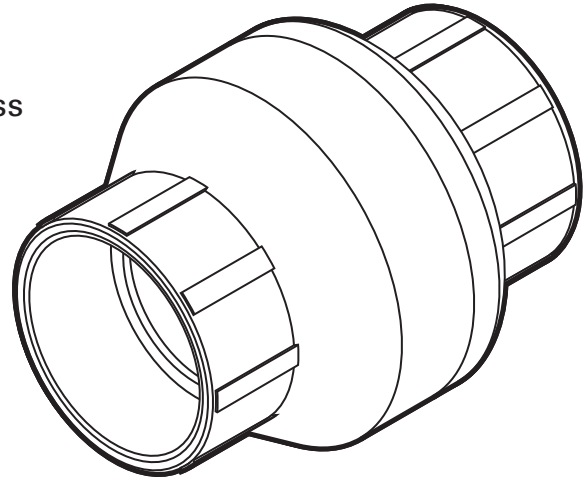

Models		L	D	Size	Case	Weight
Socket x Socket	FIPT x FIPT					
KSC-0500-S	KSC-0500-T	4.6"	2.9"	1/2"	9	4.5
KSC-0750-S	KSC-0750-T	4.6"	2.9"	3/4"	9	4.3
KSC-1000-S	KSC-1000-T	4.6"	2.9"	1"	9	3.8
KSC-1250-S	KSC-1250-T	5.1"	3.5"	1 1/4"	6	4.0
KSC-1500-S	KSC-1500-T	5.4"	3.5"	1 1/2"	6	4.2
KSC-2000-S	KSC-2000-T	6.2"	4.3"	2"	4	4.2

FEATURES COMMON TO KBI PVC PRODUCTS

- NSF listed *
- Molded in the USA by KBI
- Limited LIFETIME Warranty
- Pressure rated to 235 psi non-shock (150 working)
- Meets/Exceeds ASTM Standards
- Made with Hi-Impact PVC Type II Cell Class 15344-C
- Limited LIFETIME Warranty

