



The Professional's Choice

King Bros. Industries

29101 The Old Road, Valencia, CA 91355

Toll Free: (800) 325-9468 Fax: (661) 257-4320

E-mail: valves@kbico.com Web: www.kbico.com

Clear PVC Swing Check Compression Valve

Features:

- Swing Check flow loss insignificant due to full flow design.
- Meets/Exceeds ASTM & ANSI standards.
- Swing Check is not recommended to be installed with outlet side angled down or facing down.
- Made of clear PVC Type I material.
- Molded in the **USA** by KBI.
- 150 psi working pressure (*tested to 500 psi static @ 72°F*).

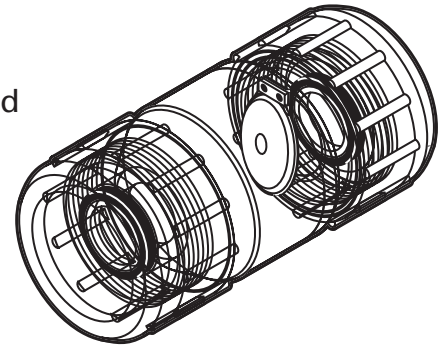

Model	Size	Connection	Case	Weight
KSCC-1250-C	1-1/4"	Comp x Comp	6	2.8
KSCC-1500-C	1-1/2"	Comp x Comp	6	3.2
KSCC-2000-C	2"	Comp x Comp	2	2.7
KSCC-3000-C	3"	Comp x Comp	1	5.0

FEATURES COMMON TO KBI PVC PRODUCTS

- NSF listed *
- Molded in the USA by KBI
- Limited LIFETIME Warranty
- 150 psi working pressure (*tested to 500 psi static @ 72°F*)
- Meets/Exceeds all ASTM Standards
- * See individual products for details

