



## The Choice of Professionals

### King Bros. Industries

29101 The Old Road, Valencia, CA 91355

Toll Free: (800) 325-9468 Fax: (661) 257-4320

E-mail: valves@kbico.com Web: www.kbico.com

# Riser-Clamp

## Features:

- Quickly, cleanly and permanently support a sprinkler riser.
- Approved for hot and cold applications (*to 200°F*).
- Meets/Exceed all applicable ASTM and ANSI standards.
- Made with superior strength brown U.V.R. Hi-Impact PVC Type II material.
- Manufactured in the **USA** by KBI.
- Beige color body.

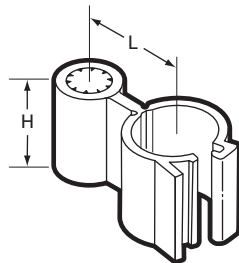
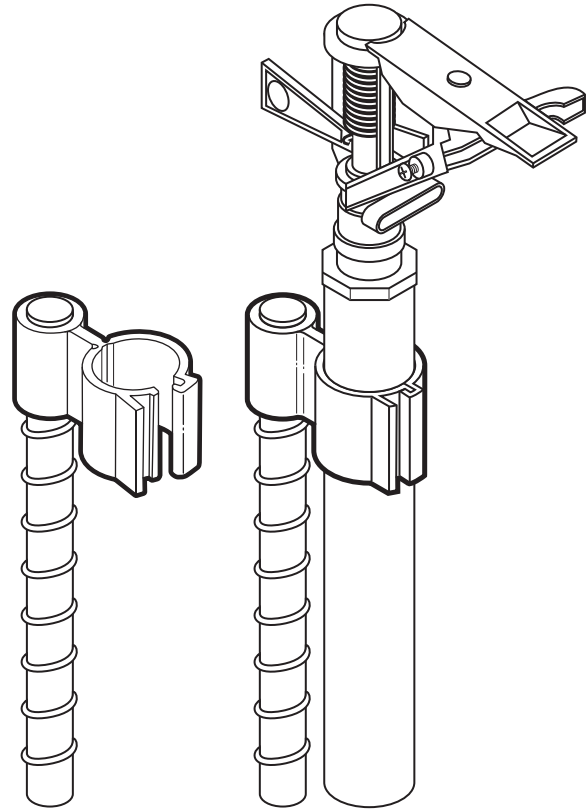

Models		Size	Height "H"	C/C "C"	Case	Weight
#3 Rebar Model	#4 Rebar Model					
RC3-0500	RC4-0500	1/2"	1/2"	1/2"	200	3.2
RC3-0750	RC4-0750	3/4"	3/4"	3/4"	200	4.4

## FEATURES COMMON TO KBI PLUMBING PRODUCTS

- Molded in the USA by KBI
- Limited LIFETIME Warranty
- Meets/Exceeds ASTM Standards
- \* See individual products for details

