



## The Choice of Professionals

### King Bros. Industries

29101 The Old Road, Valencia, CA 91355

Toll Free: (800) 325-9468 Fax: (661) 257-4320

E-mail: valves@kbico.com Web: www.kbico.com

# Acetal Sink Faucet with Hose End (IPS)

## Features:

- Approved for hot and cold applications (to 200°F).
- Tapered non-metallic valve seat and stem guarantee long wear.
- Meets/Exceeds all applicable ASTM and ANSI approvals.
- Molded in the **USA** by KBI.
- Made with high-grade copolymer material.

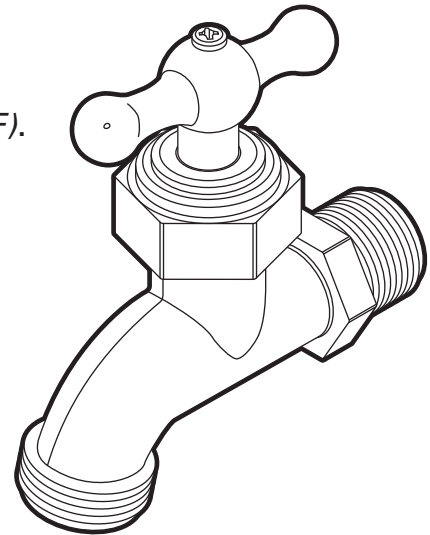

Model	Size	Connection	Case	Weight
SFT-0500-S	1/2"	MIPT x MHT	36	5.7
SFT-0750-S	3/4"	MIPT x MHT	36	5.9

### FEATURES COMMON TO KBI ACETAL PLUMBING PRODUCTS

- NSF listed \*
- Molded in the USA by KBI
- Limited LIFETIME Warranty
- Pressure rated to 100 psi @180°F
- Meets/Exceeds all ASTM Standards
- Made with Acetal Copolymer

