



The Professional's Choice

King Bros. Industries

29101 The Old Road, Valencia, CA 91355

Toll Free: (800) 325-9468 Fax: (661) 257-4320

E-mail: valves@kbico.com Web: www.kbico.com

Adjustable Check Valves (UV Matl.)

Features:

- Special order springs & seals available.
- Molded in the **USA** by KBI.
- Made with Hi-Impact UPVC Type II Cell Class 15344-CI.
- All models preset at 5 psi or 12 feet of head and can be adjusted to 14 psi or 32 feet of head.
- Adjustable for greater feet of head or psi by means of adjustment nut in the base of the unit.
- Spring & Stem: 18-8 (302 series) stainless steel.
- Threads: Meets/exceeds ASTM D-2464 & ANSI B-2.1.
- Seal Material: EPDM elastomeric seal compound #3BA712.
- Meets/exceeds ASTM D-1784 & ASTM D-2000-70B.

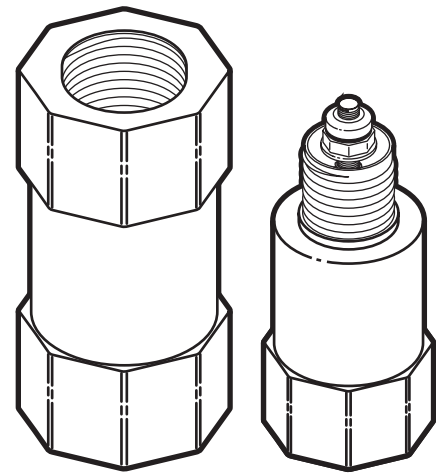

UVR Material				
Model	Size	Description	Case	Weight
UCV-0500-FF	1/2"	FIPT x FIPT	24	2.9
UCV-0500-MF	1/2"	MIPT x FIPT	24	2.9
UCV-0750-FF	3/4"	FIPT x FIPT	20	3.1
UCV-0750-MF	3/4"	MIPT x FIPT	20	3.1
UCV-1000-FF	1"	FIPT x FIPT	12	3.1

FEATURES COMMON TO KBI PVC PRODUCTS

- Molded in the USA by KBI
- Limited LIFETIME Warranty
- 235 psi working pressure (tested to 500 psi static @ 72°F)
- Meets/Exceeds all ASTM Standards
- Made with Hi-Impact PVC Type II Cell Class 15344-C
- * See individual products for details

