



The Choice of Professionals

King Bros. Industries

29101 The Old Road, Valencia, CA 91355
Toll Free: (800) 325-9468 Fax: (661) 257-4320
E-mail: valves@kbico.com Web: www.kbico.com

Commercial Grade Sch. 40 Lo-Torque™ Ball Valves

Features:

- Low torque required to operation.
- Precision molded micro-finish ball for long life and smooth movement.
- HMW-HDPE "floating seals" resist sticking.
- High quality series ideal for all residential, irrigation, industrial and commercial use.
- Patent pending "Stem-Loc design".
- Full Port Design + Schedule 80 sockets.
- Meets/Exceeds ASTM & ANSI standards.
- Molded in the **USA** by KBI.

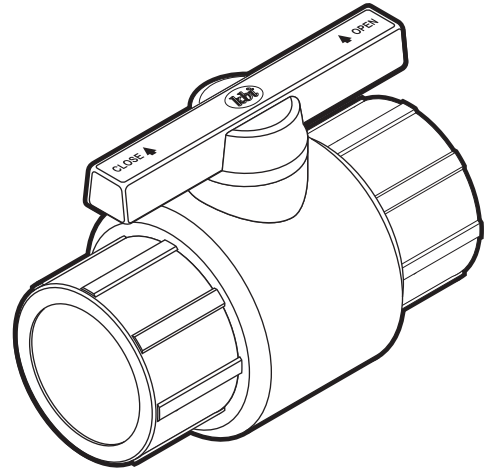

Model	Size	Description	L	D	Case	Weight
WLT-0500-S	1/2"	Slip x Slip	4.6"	2.9"	15	2.3
WLT-0750-S	3/4"	Slip x Slip	4.6"	2.9"	30	7.7
WLT-1000-S	1"	Slip x Slip	4.6"	2.9"	24	7.6
WLT-1250-S	1 1/4"	Slip x Slip	5.1"	3.5"	18	7.7
WLT-1500-S	1 1/2"	Slip x Slip	5.4"	3.5"	12	7.3
WLT-2000-S	2"	Slip x Slip	6.2"	4.3"	5	7.5

FEATURES COMMON TO KBI PVC PRODUCTS

- NSF listed *
- Molded in the USA by KBI
- Limited LIFETIME Warranty
- Pressure rated to 235 psi non-shock (150 working)
- Meets/Exceeds ASTM Standards
- Made with Hi-Impact PVC Type II Cell Class 15344-C
- Limited LIFETIME Warranty

